

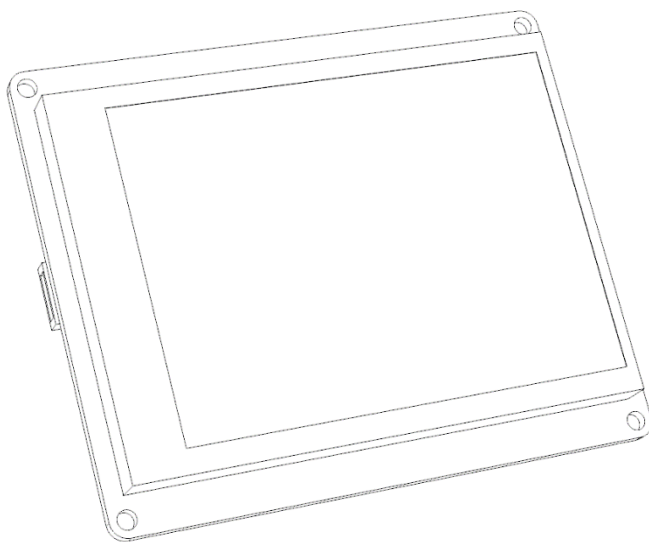

RoboPeak Mini USB Display
Datasheet

2014-5-12

Rev. 1.3



Contents

1. Introduction	2
2. Functional Overview	3
3. Pin Description	4
4. Mechanical.....	5
5. Quick Use	6
Default Firmware.....	6
First Use.....	6
Touch Screen Calibration	7
Connect to the host with the display driver installed	8
6. Development.....	9
7. Order Information.....	10
8. Contact Us	11
9. Revision History.....	12

1. Introduction

RoboPeak Mini USB Display is a low cost display module with USB connectivity for data transmission and designed by RoboPeak Team. A microchip controls the screen according to the data transferred from another side of USB port. It can be convenient used as an output device for the various embedded platforms.

This module comes with following features:

- Ease to use, zero configuration
- 320x240 resolution with 65536 color
- 2.8-inch resistive touch screen
- USB communication with up to 100fps¹ refresh frequency
- No extra power supply needed
- USB connectivity, no HDMI or VGA port needed
- Open Source driver for Linux
- Compatible with Raspberry-PI, Cuibeboard(I/II), pcDuino, WR703 and etc.

¹ Frame rate will vary with the size of current refresh data

2. Functional Overview

RoboPeak Mini USB Display has a STM32 processor with Cortex-M3 core and USB HIP to support up to 12Mbps data transmission for screen refresh. The processor monitors the resistive touch screen, processes the USB data and controls the screen.

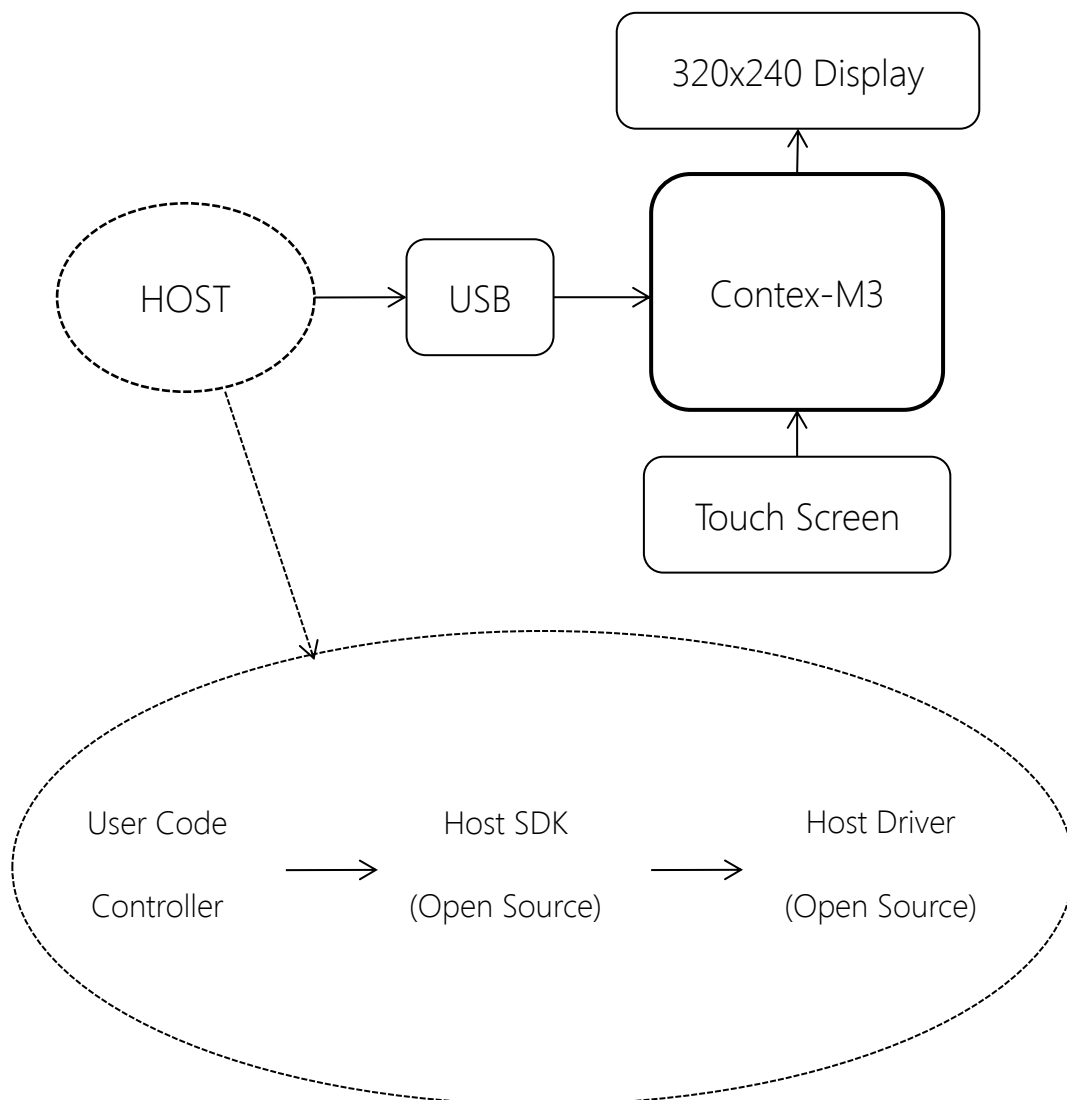

3. Pin Description

RoboPeak Mini USB Display has a Micro USB connection port (The Red Frame) and two other ports (The Yellow Frames) as a backup. The display get electricity from the USB port.

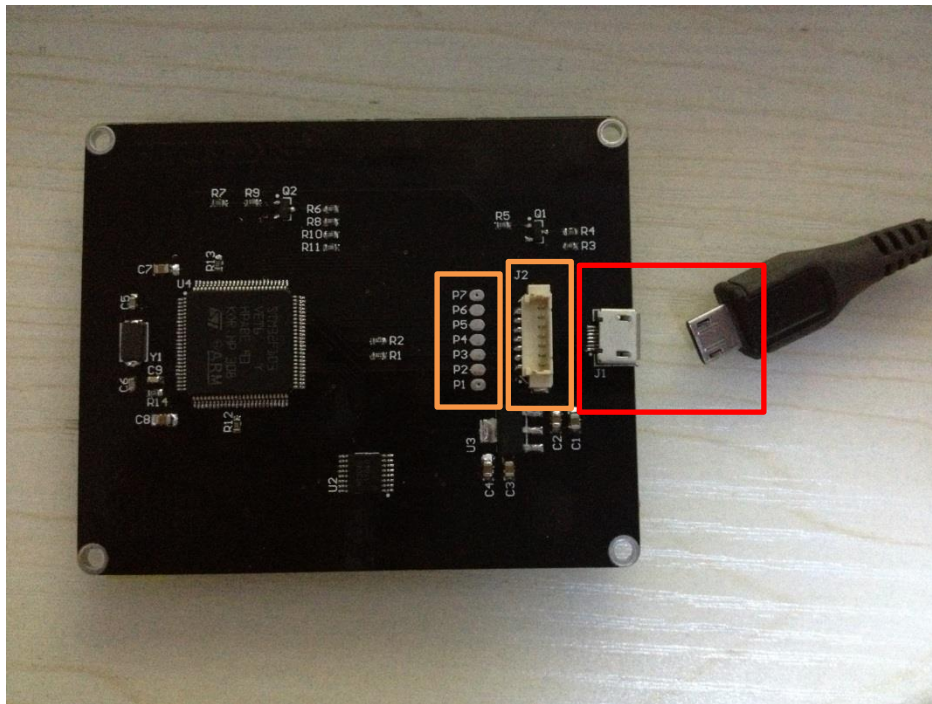

Figure 1 RoboPeak Mini USB Display Pin Description

Pad Name	Description	Min(V)	Typical(V)	Max(V)	Current(mA)
P1	Power Supply	4.8	5	5.2	200
P2	UART Tx	2.8	3.3	3.7	-
P3	USB DM	-	-	-	-
P4	USB DP	-	-	-	-
P5	BOOT0	2.8	3.3	3.7	-
P6	UART Rx	2.8	3.3	3.7	-
P7	GND	-0.1	0	0.3	-

Table 1 Pad Definition

4. Mechanical

RoboPeak Mini USB Display has a 74mm x 60.5mm board size. Please refer to the mechanical details(unit:millimeter) below within your design.

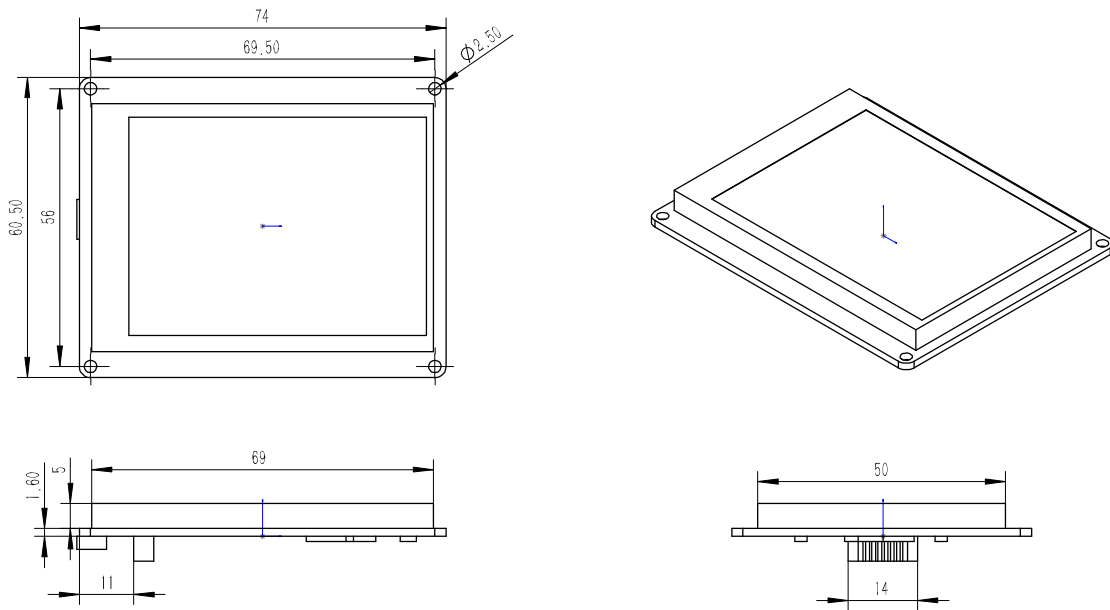

Figure 2 RoboPeak Mini USB Display Mechanical

5. Quick Use

Please refer to the RoboPeak Mini USB Display User Manual for detailed usage.

Default Firmware

RoboPeak Mini USB Display is factory with a default firmware which can be driven by RoboPeak open source driver. RoboPeak will not support the recovery if the default firmware is overwritten by user. And will not be responsible for any damage caused by the firmware change.

For detailed information to use default firmware, please refer to the SDK materials or contact RoboPeak for support.

First Use

Please prepare a micro USB cable and connect the screen to your computer.

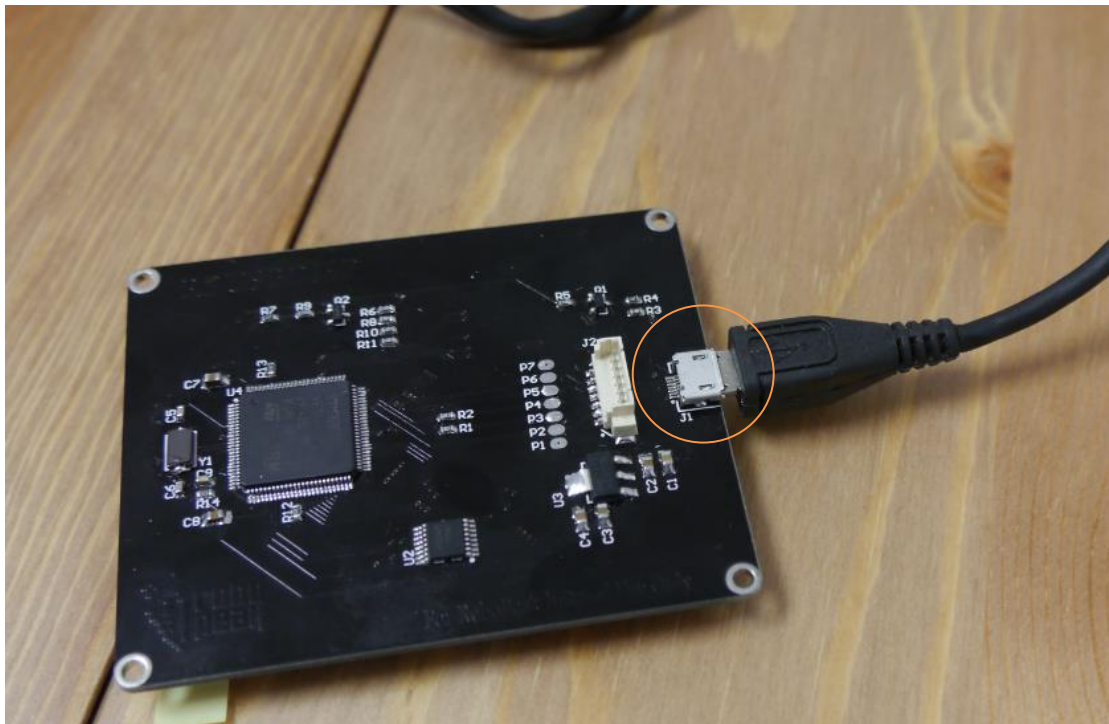

Figure 3 Connect Micro USB cord with RoboPeak Mini USB Display

The RoboPeak Logo will appear when USB is powered. And you will find the firmware version information on the top-left of the screen.



Figure 4 RoboPeak Mini USB Display Firmware Version Display

Touch Screen Calibration

A calibration has been done when factory for touch screen. If you find the calibration is not accurate, you can manually do calibration.

When you see the RoboPeak Logo while powered on, click the screen immediately until you see the calibration picture as follows. Please remember that do not click the screen before and during powering.

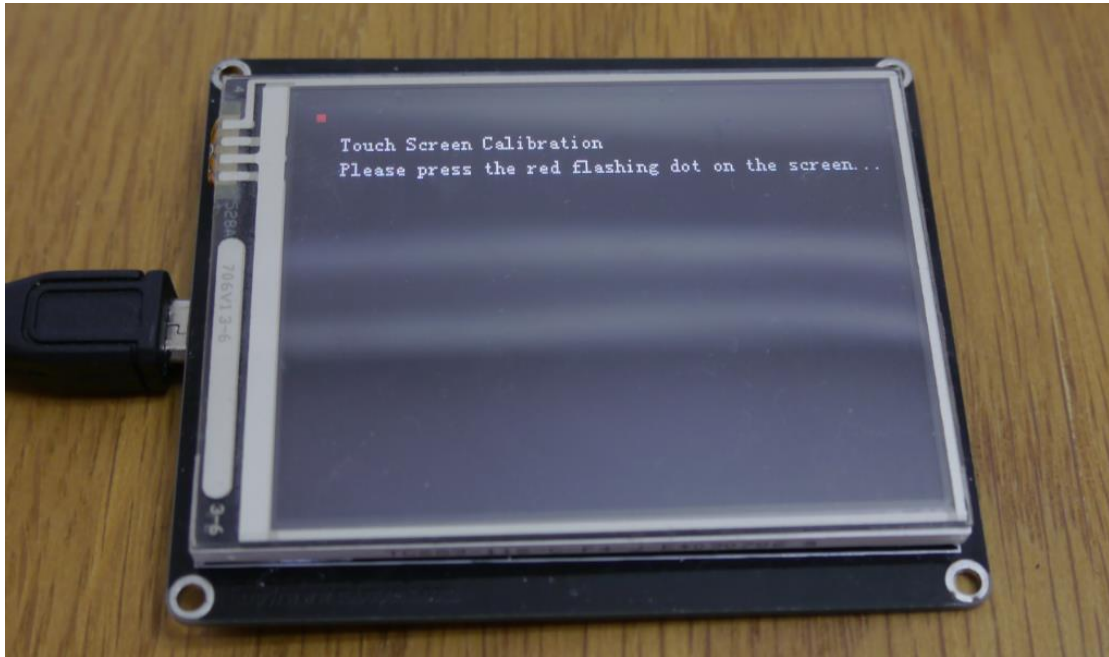

Figure 5 Touch Screen Calibration

Please use a touch screen pen to press the flashing red point. While you are pressing the point, it will turn to green. Please keep pressing it until the point moved to somewhere else on the screen.

When 3 points are touched, the calibration process is done. The calibration result will store to an area of your display' s persistent storage.

Connect to the host with the display driver installed

RoboPeak Mini USB Display works with any host Linux system with USB host sockets. You need install the related Linux kernel driver provided by RoboPeak on these systems. Please refer to the manual document for details.

6. Development

RoboPeak Mini USB Display works as a standard display module on your system, i.e. a framebuffer based display device on Linux and a touch screen device.

Customization is possible for 3rd party applications via the driver and the SDK provided by RoboPeak.

The Linux driver of RoboPeak Mini USB Display is open source. Please refer to the SDK document for more information to make the further development.

7. Order Information

Please refer to the product page on our website for details.

Order Methods List:

http://www.robopeak.com/docs/doku.php?id=product-rpusbdisp#order_formation

Product Page:

<http://www.robopeak.com/blog/?p=406>

8. Contact Us

The documents and related tools are hosted at official wiki page of RoboPeak Mini USB Display, which is located here:

| <http://www.robopeak.com/docs/doku.php?id=product-rpusbdisp>

The open source Linux driver is hosted at GitHub, the GitHub home page is:

| <https://github.com/robopeak/rpusbdisp>

This product is designed by RoboPeak Team for you, and our homepage is:

| <http://www.robopeak.com>

If you have any question or advice, please let us know via support email address:

| support@robopeak.com

9. Revision History

Date	Version	Description
2013-10-01	1.0 draft	Initial Version
2013-11-23	1.0	Style modification
2013-12-04	1.1	Added Order Info Section
2013-12-04	1.2	Fix typo
2014-05-12	1.3	Fix mech unit to millimeter